



SINGLE-LEAF SLIDING FIRE DOOR WITH MAN DOOR Type: **MARC-P1D EI120**

THANK YOU FOR YOUR TRUST AND FOR PURCHASING THE PRODUCTS FROM „MAŁKOWSKI-MARTECH” S.A.



CONTENTS

1. INTRODUCTION	3
2. APPLICATION SCOPE AND PREREQUISITES	4
2.1 INTENDED USE	4
2.2 NON-INTENDED USE	4
2.3 OHS RECOMMENDATIONS	6
2.4 SERVICE PERSONNEL REQUIREMENTS	6
3. PACKAGING, STORAGE, AND TRANSPORT	6
4. ASSEMBLY AND INSTALLATION	7
4.1 MECHANICAL INSTALLATION	7
4.2 ELECTRICAL INSTALLATION	7
5. OPERATING PRINCIPLE OF THE ELECTRICAL ACCESSORIES KIT	8
6. TECHNICAL SPECIFICATIONS	8
6.1 MARC-P1D DOOR LEAF	11
6.2 TRUCK RAIL ASSEMBLY	13
6.3 TRUCK RAIL BRACKET	16
6.4 WALL STOP	17
6.5 FRONT MODULE	18
6.6 LOWER RUNNING SHOE	19
6.7 E-MAG HOLDER ASSEMBLY	20
6.8 HEADER FASCIA	21
6.9 TRUCK RAIL FASCIA	22
6.10 FRONT MODULE FASCIA	23
6.11 MARC-EH ELECTRICAL ACCESSORIES KIT	24
6.12 MARC-VIC 0701 ELECTRICAL ACCESSORIES KIT	25
7. TROUBLESHOOTING	26
8. INSPECTION, MAINTENANCE, AND REPAIRS	27
8.1 INSPECTION & MAINTENANCE SCHEDULE	27
8.2 OPERATOR'S INSPECTIONS	28
8.3 SERVICE INSPECTIONS & MAINTENANCE	28
8.4 CLEANING & LUBRICATION	29
8.5 REPLACEMENT PARTS	29
9. DISPOSAL	29
9.1 CHEMICAL NOTICE	29
10. IDENTIFICATION	30
11. APPENDICES	31



1. INTRODUCTION

This Instructions Manual for of, Type MARC-P1D E120 single-leaf sliding fire door with a man door (henceforth the 'fire door' or the 'product') features the data and guidance for the fire door owner/user required to understand the operating principle, application, operation, and maintenance of the fire door. To ensure long-term, safe use of the fire door, the user and operating personnel shall fully understand and comply with this Manual.

The use of the fire door, including its operation, maintenance, servicing, periodic inspection, parts replacement, and repairs shall conform to this Manual.

Keep the Manual and other technical documentation appended to it safe and available to the operators and service technicians.

We reserve the right to continuous verification of the Manual contents and their adaptation to the state of the art. We hope the user understands that the Manual contents can be modified without prior notice. Some of the figures and narrative of this Manual may vary from the actual product, and if so, it is due to continuous improvement necessary due to changes in regulations of law and similar reasons; these variations do not affect the recommendations for use applicable to the product.

If this Manual is lost or damaged, contact our Customer Service and order the same version of the document.

CAUTION!

Failure in compliance with the recommendations and guidelines contained in this Manual will release the manufacturer from all liability and warranty obligations.

The servicing intended to be done by the service technicians and the user is specified further in this Manual. Only the manufacturer's authorized service may attempt assembly, installation, adjustment, parts replacement, repairs, and troubleshooting of this product.

This Manual applies to the standard accessories of the sliding fire door; the application of optional accessories, if any, is specified in the sales contract for the product.

The sliding fire door shall be used according to the engineering design developed for the intended installation location, and with consideration of the following:

- The prevailing construction and engineering standards and regulations, of which the particular ones apply:
 - a) Regulation of the European Parliament and of the Council (EU) No. 305/2011 of 9 March 2011 laying down harmonised conditions for the marketing of construction products and repealing Council Directive 89/106/EEC (OJ L. EU L88 of 04.04.2011, as amended);
 - b) Polish Construction Products Act of 16 April 2004 (Dz.U. 2019.266.730);
 - c) Polish Building Code Act of 7 July 1994 (Dz.U. 2019.1186, as amended);
 - d) Polish Act of 13 April 2016 on the Conformity System and Market Surveillance (Dz.U. 2019.544);
 - e) Polish Fire Protection Act of 24 August 1991 (Dz.U. 2019.1372/1518/1593);
 - f) Polish Regulation of the Minister of Infrastructure and Construction dated 17 November 2016 and concerning the Practice of Declaration of Performance for and Construction Mark Labelling of Construction Products (Dz.U. 2016.1966);
 - g) Polish Regulation of the Minister of the Interior and Administration dated 7 June 2010 and concerning the Fire Protection of Buildings, Structures, and Land (Dz.U. 2010.109.719, as amended);
 - h) Polish Regulation of the Minister of Infrastructure dated 12 April 2002 and concerning the Technical Requirements for Buildings and Locations Thereof (Dz.U. 2015.1422, as amended);
 - i) EN 16034:2014-11 (Harmonised standard), Pedestrian doorsets, industrial, commercial, garage doors and openable windows – Product standard, performance characteristics – Fire resisting and/or smoke control characteristics;
 - j) PN-EN 13501-2:2016-07, Fire classification of construction products and building elements – Part 2:



- Classification using data from fire resistance tests, excluding ventilation services;
- k) EN 13241+A2:2016-10 (Harmonised standard), Industrial, commercial, garage doors and gates – Product standard, performance characteristics;
 - l) PN-EN 12635+A1:2010, Industrial, commercial and garage doors and gates – Installation and use;
 - m) PN-EN 12424:2002 Industrial, commercial and garage doors and gates – Resistance to wind load – Classification;
- The Declaration of Performance;
 - These Instructions for Use, Operation and Maintenance.

Pursuant to the EN standard (i) and the Regulation (f), the fire door is a construction product eligible for System 1 of Assessment and Verification of Constancy of Performance.

Based on the Regulation (a), the manufacturer who markets a construction product is required to issue its Declaration of Performance (DoP) and apply a legible CE marking label to the product.

CAUTION!

A copy of the Declaration of Performance and the Warranty Certificate are provided by the manufacturer to the user after the acceptance of the installation/assembly of the fire door, in accordance with the sales contract (and/or the quotation).

A copy of the Declaration of Performance and the Warranty Certificate for the fire door is an integral part of this Manual and shown as its Appendices, ref. Section 11 APPENDICES.

The CE marking of the fire door is placed on its nameplate, ref. Section 10 IDENTIFICATION.

The valid list of authorized providers of product installation, service inspections, and maintenance (complete with assessment and certification of proper performance of these services) is available on the official website of the fire door manufacturer (www.malkowski.pl).

2. APPLICATION SCOPE AND PREREQUISITES

2.1 INTENDED USE

Type MARC-P1D EI120 single-leaf sliding fire door is a vertical, moving fire partition intended as the closure of a passageway between fire partitioned zones inside of industrial buildings, warehouse rooms, technical access floors in office buildings, hospitals, and other public buildings.

The standard version of type MARC-P1D sliding fire door is manufactured in the declared use category C0 (with the number of cycles 1 to 499 per EN 16034:2014-11) and wind load resistance class 1 (per PN-EN 12424:2002).

On special request, type MARC-O MARC-P1D sliding fire door can be manufactured in the declared use category **1** (500 to 9,999 cycles) or **2** (10,000 to 49,999 cycles) or **3** (50,000 to 99,999 cycles) or **4** (100,000 to 199,999 cycles) or **5** (> 200,000) and wind load resistance class **2, 3** or **4**.

2.2 NON-INTENDED USE

Type MARC-P1D EI120 sliding fire door is not intended for the following applications:

- In Ex-zones (explosion hazard areas), unless qualified as intended for the application following suitable modifications by the manufacturer;
- In environmental conditions with presence of salinity, salts, acids, alkali, and/or other aggressive chemical (including cement and lime) which trigger corrosion (the maximum permitted relative humidity is 80% for this product);
- When exposed to strong electromagnetic fields (> 0.1 T);
- In areas with wind exposure with a force higher than the wind load resistance class stated on the nameplate and a copy of the Declaration of Performance.

CAUTION!

The PN-EN 12424:2002 wind load resistance has been determined for the closed door. Operation of the



MAŁKOWSKI MARTECH Czołowo, ul. Leśna 57, 62-035 Kórnik phone: +48 61 222 75 00 fax: +48 61 222 75 01 email: biuro@malkowski.pl, www.malkowski.pl	SLIDING FIRE DOOR type: MARC-P1D EI120	Ref. no.: ISOiK_P-4
	INSTRUCTIONS FOR USE, OPERATION AND MAINTENANCE	Revision: 03/2021

door in high winds can be hazardous!

Never attempt to:

- have the fire door assembled by a contractor who has not been authorized by the product manufacturer;
- repair, troubleshoot, improve, alter, modify, or replace or retrofit components or parts outside of the specification limits shown in this Manual and/or without a prior written authorization from the fire door manufacturer (ref. the manufacturer's authorization matrix in Section 6 TECHNICAL SPECIFICATION);
- install any parts or components which are non-genuine or non-original or not specified and/or authorized by the fire door manufacturer;
- operate the fire door which is defective, out of order or partially or wholly incompatible with the specified properties or intended use (due to damage from fire, a building collapse, etc.);
- operate the fire door without the required operator's inspections, periodic service inspections, and/or maintenance done as specified in this Manual (ref. Section 8 INSPECTION, MAINTENANCE, AND REPAIRS) or as specified in the custom provision of the sales contract concluded between the user and the manufacturer of the fire door;
- operate the fire door with mechanical damage or other defects caused by misuse, especially if it has been stopped in an emergency and the reason has not been cleared;
- operate the fire door if it or any of its components have been found to work abnormally and the relevant supervisor, maintenance team and the manufacturer's technical service have not been notified;
- operate the fire door with its nameplate defaced or removed;
- service or repair the fire door when its components are in motion;
- walk, run, or drive through the fire door in motion;
- wash or clean the fire door with formulas that are corrosive and/or based on any acid or solvent, or pressure clean with any liquid (see Section 8.4 CLEANING AND LUBRICATION).

Failure to comply with the foregoing restrictions will have the user lose all liabilities and warranty obligations of the manufacturer towards the former, including loss of the declared fire resistance and the DoP issued by the manufacturer.

CAUTION!

The manufacturer shall be released from their liability and warranty obligations:

- if the product has been installed by a contractor not authorised by the manufacturer;
- for all natural, whether partial or complete, wear and tear resulting from the characteristics or intended use of the fire door (which includes exposure to fire);
- if the user or any third party alters, modifies, or replaces components or structural features of the fire door without coordination and prior written authorisation of the manufacturer;
- for misuse or failure in routine maintenance of the fire door or its components as required by this Manual;
- for failure in the periodic inspections required in this Manual or any binding, custom agreement with the manufacturer or its authorized technical service, if the failure has caused damage and other defects (including the defacement or removal of the nameplate).

In the foregoing circumstances the manufacturer does not warrant that the declared fire resistance of the door will be maintained any longer.

To ensure reliable operation and compliance with the warranty terms and conditions, please contact MAŁKOWSKI-MARTECH S.A. or its commercial partner for product training. The purpose of the training is to provide the necessary information about proper use and, among others, the requirements for operating personnel.



MAŁKOWSKI MARTECH Czołowo, ul. Leśna 57, 62-035 Kórnik phone: +48 61 222 75 00 fax: +48 61 222 75 01 email: biuro@malkowski.pl, www.malkowski.pl	SLIDING FIRE DOOR type: MARC-P1D EI120	Ref. no.: ISOiK_P-4
	INSTRUCTIONS FOR USE, OPERATION AND MAINTENANCE	Revision: 03/2021

2.3 OHS RECOMMENDATIONS

The operation of the fire door requires compliance with the prevailing general occupational health and safety laws, including legal prerequisites of fire protection and timely inspections, servicing, maintenance, parts replacement, and repairs which are specified in the requirements. Do not operate the fire door if it has been stopped in an emergency until the root cause is cleared.

Follow the prevailing regulations of law for waste generation control and proper disposal during all work on the fire door. Special caution is required that during cleaning/washing, maintenance, replacement of parts or repairs of the fire door no harmful substances are released into the soil or sewers, like lubricants, solvent-borne cleaning agents, etc. These substances must be collected, contained and shipped for legal disposal in suitable containers.

2.4 SERVICE PERSONNEL REQUIREMENTS

The servicing of the fire door requires no professional license. The fire door shall be operated and serviced by an operator (e.g. a maintenance technician) designated by the fire door user. The designated operator requires operating training from the fire door manufacturer's representative or the manufacturer's authorized installation contractor; once completed, the operating training must be certified as such in writing.

The user shall ensure that the operating personnel is and remains trained in occupational health and safety, including the possible risks of this product, the job safety instructions, this Manual, and all instructions attached to this document.

3. PACKAGING, STORAGE, AND TRANSPORT

Depending on the sales contract/quotation provisions agreed to with the manufacturer, the fire door can be collected from the manufacturer's warehouse or shipped and delivered by the manufacturer to the installation side against a written proof of acceptance of the product quantity and quality on the Goods Issue Note.

The fire door is delivered in assemblies and components to be assembled and installed at the user's site. Each assembly and component is separately protected against mechanical damage for the duration of shipping as follows:

- the door leaf panes are stacked on a pallet no smaller than the single panel dimensions when laid flat, with waste wool or expanded polystyrene spacers between the panels, with the palletized stack wrapped in film and bound with straps over square timber pieces for protection of the product's edges;
- the trim pieces are placed on spacers of mineral wool or expanded polystyrene either on the door leaf panel pallet or on a separate pallet;
- small accessory items, like fasteners, etc. are packed in a separate cardboard box;
- each delivery packaging is labelled with the packing list of the assemblies and components, showing the customer's purchase order, the assembly number, the fire door type, and the DoP reference number.

Transport, storage, and assembly/installation of the fire door are regulated as follows:

- The assemblies, components, and single parts of the fire door must be properly secured in transport (with lashing, straps, spacers, etc.);
- Following the unloading from delivery and for the duration of storage, store all parts of the fire door in a sheltered room, away from sources of damage, dirt, and the elements (like snow and rain);
- Do not step, walk, or drive over any assembly, component, or part of the fire door; do not place any loads, tools, or any chemicals on these items; do not lead on these items; do not attempt anything unspecified here which might contribute to damage and reduction of value/quality of the fire door items.



MAŁKOWSKI MARTECH Czołowo, ul. Leśna 57, 62-035 Kórnik phone: +48 61 222 75 00 fax: +48 61 222 75 01 email: biuro@malkowski.pl, www.malkowski.pl	SLIDING FIRE DOOR type: MARC-P1D EI120	Ref. no.: ISOiK_P-4
	INSTRUCTIONS FOR USE, OPERATION AND MAINTENANCE	Revision: 03/2021

4. ASSEMBLY AND INSTALLATION

The electrical and mechanical installation and assembly of the fire door shall only be done by trained personnel of the manufacturer or its authorized installation contractors.

Fire door pre-installation/assembly procedure:

- Before attempting the work, inspect all delivery items for incorrect quantity and damage during transport or storage;
- Verify conformity of the installation conditions against the purchase order / sales contract drawing;
- All connections and joints must be carefully made and assembled and re-checked for proper tightening and fit.

Install the fire door in compliance with the INSTALLATION INSTRUCTIONS (ref. Section 11 APPENDICES), and follow with the installation work inspection and functional testing.

The acceptance of the installed fire door is to be done in witness of the buyer's authorized and the manufacturer's authorized representatives (it can be witnessed on behalf of the manufacturer, by the authorized installation contractor) who will certify the acceptance in the Periodic Inspection and Maintenance Log (appended to this Manual) or in a separate installation acceptance certificate.

4.1 MECHANICAL INSTALLATION

The assembly/installation of the mechanical components of the fire door shall proceed in compliance with the INSTALLATION INSTRUCTIONS (ref. Section 11 APPENDICES), which are dedicated engineering documents intended only for the installation contractor's foremen who hold the relevant installation certificates issued by the fire door manufacturer.

CAUTION!

For proper handling, lifting, and fastening of the fire door structure, ensure proper OHS conditions and the work equipment required for the tasks, like ladders of suitable height, fall arrest harnesses, lifelines and other gear, e.g. slings, lifting beams, a hoist, or a MEWP with a lift capacity and outreach sufficient for the weight and installation height of the product's structure.

The sales contract specifies the party required to secure the work equipment for the assembly, installation, and periodic inspections/maintenance processes.

4.2 ELECTRICAL INSTALLATION

The configuration of the electrical accessories for the fire door depends on the purchase order specifications and their installation must conform to the engineering documentation (for the installation contractor) appended to this Manual.

The electrical wiring diagram is shown inside of the control panel cover and in the electrical accessories installation manual appended to this Manual (ref. Section 11 APPENDICES).

CAUTION!

The fire door user shall prepare the electrical power connection at the fire door installation site for this product. The electrical power connection shall have compatible electrical and protection ratings to permit wiring to the fire door, its functional testing, and normal operation.

The electrical power connection must be wired to the fire door electrical accessories, tested, and repaired whenever it fails by a suitably licensed professional electrician only.



5. OPERATING PRINCIPLE OF THE ELECTRICAL ACCESSORIES KIT

The primary function of the electrical accessories (ref. Sections 6.11 to 6.12 ELECTRICAL ACCESSORIES KIT) is to automatically operate the fire door to close whenever a fire hazard is detected and signalled. A detailed description of the structure, installation and operation of the fire alarm and detection accessories delivered with the fire door is included in the electrical accessories installation manual appended to this Manual.

The fire door leaf is retained within the truck rail assembly and held open with an e-mag holder or an electric motor wired to a fire-safety power supply, which in turn can be factory-provided with a fire alarm control panel or wired directly to the on-site fire alarm system.

If smoke / heat sensors detect a hazard of fire, the fire alarm control panel or the fire-safety power supply is triggered by the fire detection signal to:

- isolate live voltage from the e-mag holder and release the counterweight;
- or
- the fire-safety power supply energizes the fire door motor which operates the leaf to close (optional).

The result is the closing motion of the door (operated by the movement of cables, a chain, or a toothed belt, as applicable).

The door leaf can be alternatively released manually, with a dedicated emergency close button wired to the control panel.

When the reason for the fire alarm signal is clear, the control panel reverts to normal operation; now, the fire door leaf must be manually operated to open until the e-mag holder contacts are made.

6. TECHNICAL SPECIFICATIONS

Specification	Value	Notes
Fire resistance class	EI ₂ 120	-
Closing speed	< 0.30 m/s	-
Operation (manual / powered)	-	Operation by movement of the counterweight or the (optional) electric drive unit
Leaf colour	Any in the RAL palette On request	Standard colours: RAL 9002, 9010, 7035
Fascia colour		



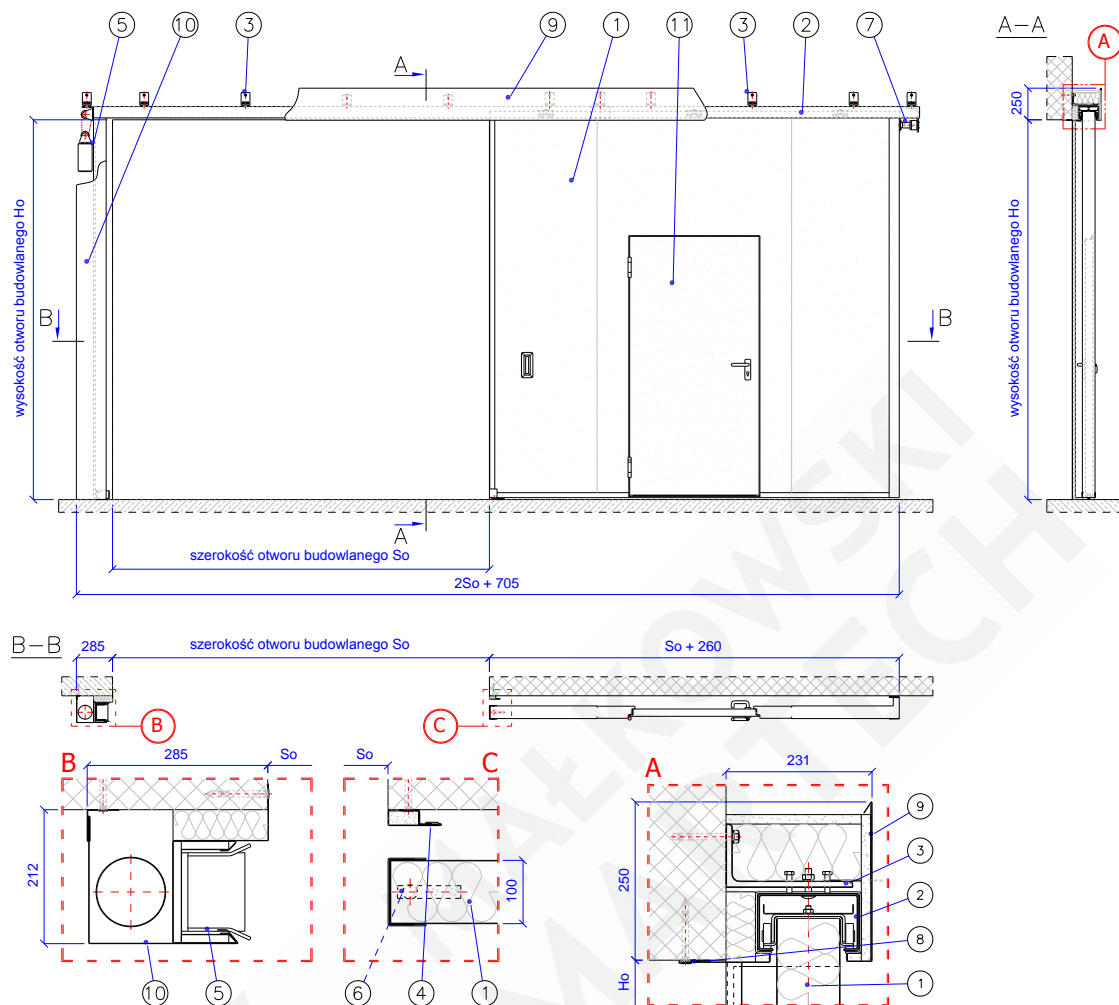

wysokość otworu budowlanego Ho	Clear opening height Ho
szerokość otworu budowlanego So	Clear opening width So

Fig. 1 – MARC-P(1D)120-01.00.00 [Type MARC-P1D EI120 single-leaf sliding fire door with man door]

1 – Door leaf; 2 – Truck rail; 3 – Truck rail bracket; 4 – Wall stop; 5 – Front module; 6 – Lower running shoe; 7 – E-mag holder assembly; 8 – Header fascia; 9 – Truck rail fascia; 10 – Front module fascia

List of components for type MARC-P1D EI120 sliding fire door

#	Designation	Quantity	Drawing no./ Part no. / Standard
1	Door leaf	1	2 – MARC-P(1D)120-01.01.00
2	Truck rail assembly	1	4 – MARC-P(1D)120-01.02.00
3	Truck rail bracket	*	5 – MARC-P(1D)60-01.03.00, * – Depends on the door width
4	Wall stop	1	6 – MARC-P(1D)120-01.04.00
5	Front module	1	7 – MARC-P(1D)120-01.05.00
6	Lower running shoe	1	8 – MARC-P(1D)120-01.06.00
7	E-mag holder assembly	1	9 – MARC-P(1D)120-01.07.00
8	Header fascia	1	10 – MARC-P(1D)120-01.08.00



MAŁKOWSKI MARTECH Czołowo, ul. Leśna 57, 62-035 Kórnik phone: +48 61 222 75 00 fax: +48 61 222 75 01 email: biuro@malkowski.pl, www.malkowski.pl	SLIDING FIRE DOOR type: MARC-P1D EI120	Ref. no.: ISOiK_P-4
	INSTRUCTIONS FOR USE, OPERATION AND MAINTENANCE	Revision: 03/2021

9	Truck rail fascia	1	11 – MARC-P(1D)120-01.09.00
10	Front module fascia	1	12 – MARC-P(1D)120-01.10.00
11	Man door	*	* – Depending on the PO specifications; the standard kitting features 1 pc.

LIST OF ANCHORING FASTENERS FOR THE TRUCK RAIL BRACKETS

NOTE: 1. The standard set of fasteners supplied with the door includes the hardware for installation on concrete (C20/25) and reinforced concrete walls.

2. It is possible to use different fasteners provided if they are marketed with the CE marking or the Polish Construction Mark “B” and have the same or better strength and the same intended use.

#	Anchoring fasteners	Notes
A. REGULAR/PRESTRESSED CONCRETE HOLLOW CORE SLABS		
A.1	Hollow core slab anchor Fischer FHY; Hilti HKH	- the size and type are specified for the transmitted loads;
A.2	Sleeved anchor e.g. Fischer EA II; Hilti HKD	
B. WALLS, FLOORS, AND BEAMS OF SOLID/RF CONCRETE		
B.1	Bolt anchor e.g. MKT BZ; Fischer FAZ II; Hilti HST3	- the size and anchoring depth are specified for the transmitted loads;
B.2	Threaded anchor e.g. Fischer FBS II; Hilti HUS HR/CR	
B.3	Chemical anchoring with threaded bars e.g. MKT VM Multi-plus; Fischer FIS SB	- Min. bar size M8 (DIN 976), min. strength class 8.8 (PN-EN ISO 898-1)
C. MASONRY WALLS OF CELLULAR CONCRETE UNITS (e.g. Ytong, Solbet, or Termalica)		
C.1	Threaded anchor e.g. Fischer FBS II; Hilti HUS HR/CR	- The size and anchoring depth are specified for the transmitted loads;
C.2	Chemical anchoring with threaded bars e.g. MKT VM Multi-plus; Fischer FIS V/FIS P	- Min. bar size M8 (DIN 976), min. strength class 8.8 (PN-EN ISO 898-1)
C.3	Through-and-through fastening with threaded bars	- DIN 976 bar; the size is specified for the transmitted loads; min. strength class 8.8 (PN-EN ISO 898-1) - PN-EN ISO 4032 nut, min. strength class 8; - PN-EN ISO 7093 wide washer 200 HV;
D. SOLID MASONRY WALLS (e.g. concrete units, sand lime blocks, solid bricks) OR HOLLOW MASONRY WALLS (e.g. slotted hollow bricks, round hollow core bricks, Porotherm)		
D.1	Chemical anchoring with threaded bars e.g. MKT VM Multi-plus; Fischer FIS V/FIS P	- Min. bar size M8 (DIN 976), min. strength class 8.8 (PN-EN ISO 898-1)
D.2	Threaded anchor e.g. Fischer FBS II; Hilti HUS HR/CR	- the size and anchoring depth are specified for the transmitted loads;
D.3	Through-and-through fastening with threaded bars	- Ref. C.3 – the washers need to be replaces; - PN-EN ISO 4079 washer, 200 HV;
E. FIRE-PROOFED STEEL STRUCTURES AND FIRE STUD WALLS ¹⁾		
E.1	Threaded fastening	- PN-EN ISO 4014 / 4017 bolt; the size is specified for the transferred loads; min. strength class 8.8 (PN-EN ISO 898-1) - PN-EN ISO 4079 washer, 200 HV; - PN-EN ISO 4032 nut, min. strength class 8;

1) – The inner steel profiles must withstand the static and dynamic loads of the fire door installation and operation.



MAŁKOWSKI MARTECH Czołowo, ul. Leśna 57, 62-035 Kórnik phone: +48 61 222 75 00 fax: +48 61 222 75 01 email: biuro@malkowski.pl, www.malkowski.pl	SLIDING FIRE DOOR type: MARC-P1D EI120	Ref. no.: ISOiK_P-4
	INSTRUCTIONS FOR USE, OPERATION AND MAINTENANCE	Revision: 03/2021

LIST OF ANCHORING FASTENERS FOR WALL STOPS, FASCIAS AND THE FRONT MODULE ²⁾

F. RF WALLS, CELLULAR CONCRETE MASONRY WALLS, AND HOLLOW OR SOLID MASONRY WALLS		
F.1	Steel wall plug (frame anchor)	- M8; M10; - Min. length 72 mm;
F.2	Plastic frame anchor plug, Hilti HRD-CR	- Size 8; 10, - Min. length 60 mm;
F.3	Steel sheet screws e.g. Hilti S-MD; Stalco WS / FD / FM; Etanco GT	- min. St 4.8 x 25 (DIN 7504); - The size is specified for the transferred loads and thickness of the mating component walls

2) – All hardware listed in B, C, D, and E may also be used.

6.1 DOOR LEAF

The door leaf is the primary component of the sliding fire door. When closed, it forms a sealed, integral partition with the fire resistance rating of EI120.

The door leaf is 100 mm thick and comprises vertically oriented panels which can be 400 to 1200 mm wide, the top profile, the bottom profile, bracing hardware, and cladding of 0.5 to 0.7 mm thick galvanized sheet steel. Each door leaf panel has a core of mineral wool, P/N PRO_{MM}17. Inside of each panel mineral wool core are dia. 8.0 mm vertical bars of PN-EN 10025-2:2019-11 grade S235JR steel, both ends of which are tapped and they tie the top profile with the bottom profile with M8 nuts and washers.

On both sides of the door leaf, the mineral wool core panels are bonded with adhesive, P/N PRO_{MM}2, PRO_{MM}12, or O-PA to vertically oriented galvanized steel sheets, PN-EN 10346:2015-09 grade DX51D+Z275, and 0.5 to 0.7 mm thick.

The top profile is a U-section made of 3.0 mm thick steel sheet, PN-EN 10346:2015-09 grade DX51D+Z275, and the bottom profile is a hat profile made of the same sheet steel grade which is 2.0 mm thick.

Along the labyrinth edge of the door leaf is a 2.0 mm sheet steel profile installed with two fire-proof panel strips, P/N PRO_{MM}3. The steel closing profile acts as vertical labyrinth closure which has an intumescent seal along the whole height, P/N PRO_{MM}15.

The header edge of the door leaf is clad on both sides with fire-proof panel strips, P/N PRO_{MM}3. The gate leaf edges (save for the header edge) are finished with 0.5–0.7 mm thick grade DX51D+Z275 steel sheet profiles fastened with steel rivets to the bottom profile and the cladding sheet sheets.

The door leaf features a single, solid-leaf steel hinged man door, type MARC-DB, with the fire resistance rating equal to that of the fire door. The man door clear opening dimensions depend on the PO specifications. The man door standard version features a mortice sashlock with a steel-shanked folding handle from Małkowski-Martech S.A. on one side and a standard door handle or a panic lever on the other side of the door.

It is possible to use different hardware in the man door if the hardware is marketed with the CE marking and has been certified for application with the fire door.

The man door opening direction is as specified in the PO.



Door leaf specifications

Specification	U.m.	Value	Notes
Width / height / thickness	mm	So ¹⁾ + 235 / Ho ²⁾ + 55 / 60	-
Colour	-	Any in the RAL palette on request	Standard colours: RAL 9002, 9010, 7035
Quantity	pcs.	1	-
Total weight	kg / m ²	35	-

1) – Door (construction partition) clear opening width; 2) – Door clear height

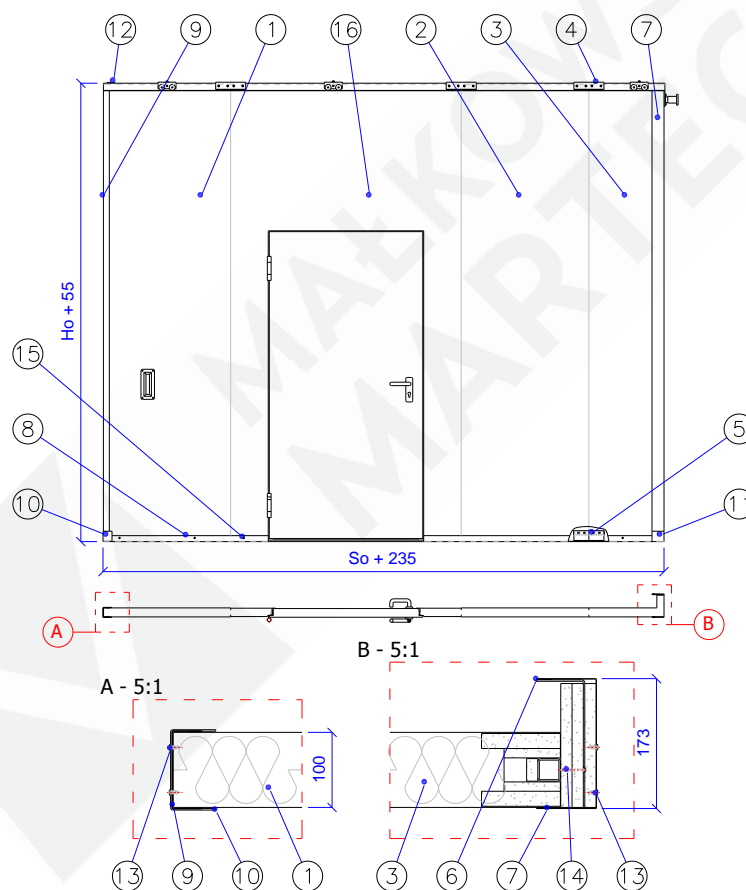
Fig. 2 – MARC-P(1D)120-01.01.00 [Door leaf]

- 1 – Front panel; 2 – Middle panel; 3 – Tail panel; 4 – Top union; 5 – Bottom union;
 6 – Edging strip; 7 – Edging strip guard; 8 – Threshold guard; 9 – Front fascia;
 10 – Front bottom hardware; 11 – Tail bottom hardware; 12 – Cable latch; 13 – St4.8x16 screw; 14 – St6.3x45 screw;
 15 – 4x14 mm pop rivet; 16 – Door module complete with the man door



MAŁKOWSKI MARTECH Czołowo, ul. Leśna 57, 62-035 Kórnik phone: +48 61 222 75 00 fax: +48 61 222 75 01 email: biuro@malkowski.pl, www.malkowski.pl	SLIDING FIRE DOOR type: MARC-P1D EI120	Ref. no.: ISOIK_P-4
	INSTRUCTIONS FOR USE, OPERATION AND MAINTENANCE	Revision: 03/2021

Door leaf: list of components

#	Designation	Fig.	Replacement / Repair			Notes
			U ¹⁾	A ²⁾	P ³⁾	
1	Front panel	1	-	-	YES	-
2	Middle panel	*	-	-	YES	* – Depends on the door width
3	Tail panel	1	-	-	YES	-
4	Top union, 74 x 42 x 3 channel bar	*	-	YES	YES	* – Number of all panels: 1
5	Bottom union, 30 x 20 x 2 channel bar	*	-	YES	YES	* – Number of all panels: 1
6	Edging strip	1	-	YES	YES	-
7	Edging strip guard	1	-	YES	YES	-
8	Threshold guard	2	-	YES	YES	-
9	Front fascia	1	-	YES	YES	-
10	Front bottom hardware	1	-	YES	YES	-
11	Tail bottom hardware	1	-	YES	YES	-
12	Cable latch	1	-	YES	YES	-
13	4.8 x 16 screw	*	YES	YES	YES	* – Every 500 mm, not less than 3 rows of; DIN 7504 P / ISO 15482
14	6.3 x 45 screw	*	YES	YES	YES	* – Every 500 mm, not less than 3 rows of; DIN 7504 P / ISO 15482
15	4 x 14 pop rivet	*	YES	YES	YES	* – Every 500 mm, PN 82971 / DIN 7337
16	Door module	*	-	-	YES	* – Depends on the PO specifications, the standard kitting features 1 pc.

1) – Done by the user, 2) – Done by the authorized service, 3) – Done by the manufacturer

CAUTION! If the parts to be serviced by manufacturer only is replaced by anyone else, it will immediately void the CE marking of the door and the door's performance, including the fire resistance rating.

6.2 TRUCK RAIL (RUNNING SYSTEM)

The running system of the door comprises steel trucks made by Małkowski-Martech S.A., a steel truck rail, and the closing system operated with a counterweight (or an optional drive unit).

Each steel trolley comprises two pairs of OD 40 mm steel bearings attached to the steel body of the truck.

The truck rail cross section measures 160 x 90 mm and it is made of 3.0 mm thick steel sheet profiles, PN-EN 10346:2015-09 grade DX51D+Z275.

The truck rails are fastened to the construction partition with steel brackets made of 150 x 100 mm angle bars (PN-EN 10056-2:1998+Ap1:2003) or steel brackets made of 100 x 50 x 5 mm cold-formed channel bars. The anchoring fasteners depend on the material of the construction partition. The truck rail and the steel top profile of the door leaf form a labyrinth joint. Along the vertical labyrinth joint there are intumescent seals installed, P/N PRO_{MM}15.



The truck rail running system is protected with cladding of fire-proof panel strips, P/N PRO_{MM3} and shielded with profiles made of 0.5 to 0.7 mm thick grade DX51D+Z275 steel sheet.

The closing system is formed by an electromagnetic holder, cable pulleys with a steel cable the minimum dia. of which is 3.0 mm, and counterweights made of coiled steel sheet or solid steel discs.

Optionally, the doors can be operated with type VIC electric drive units from Małkowski-Martech S.A.

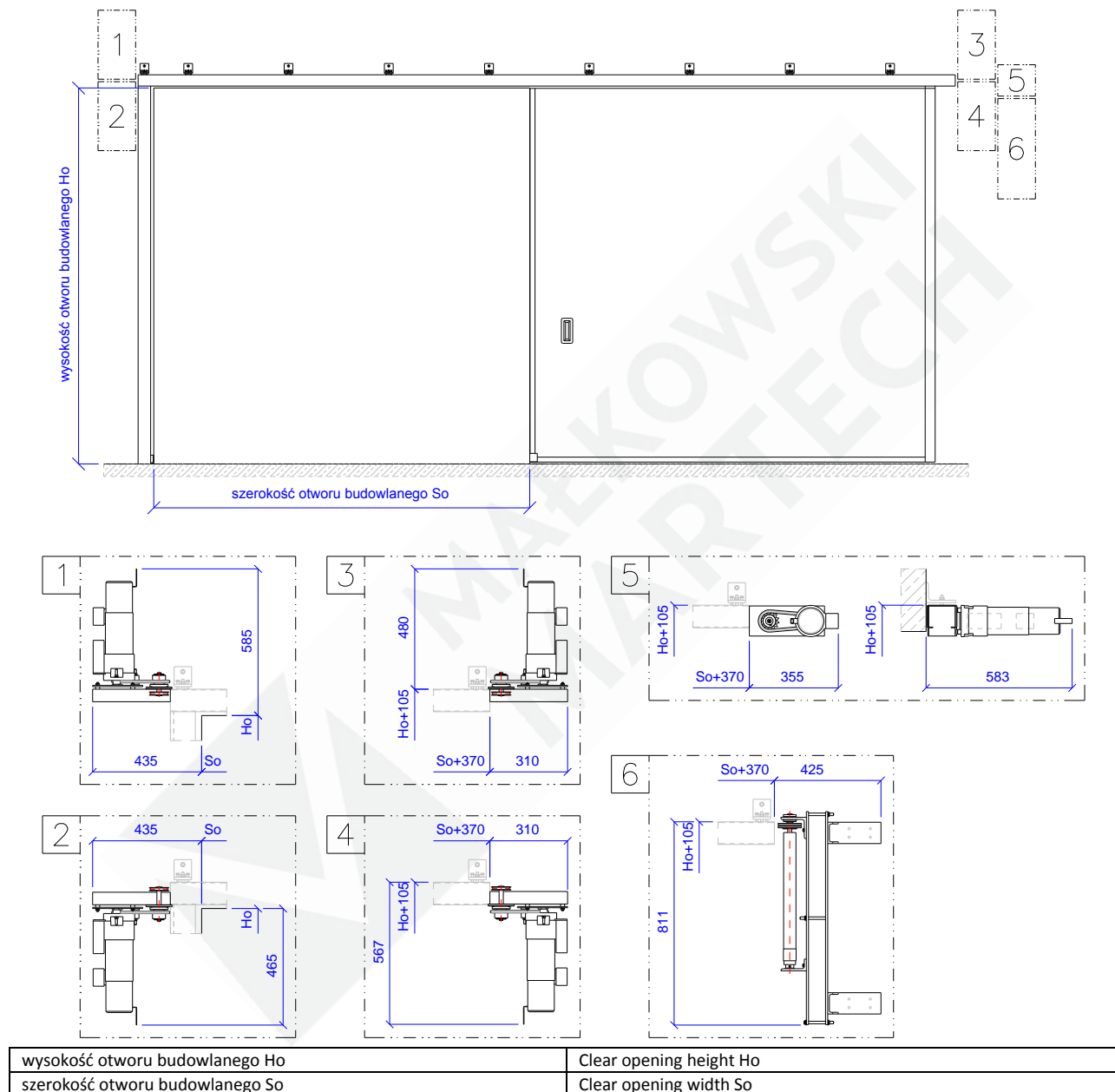

Fig. 3 – Installation versions of type VIC electric drive unit



Truck rail specifications

Specification	U.m.	Value	Notes
Width / height / length	mm	120 / 90 / So ¹⁾ + 835	-
Colour	-	galvanized	Any in the RAL palette on request
Quantity per door	sets	1	-
Total weight	kg/m	8.75	-

1) – Door (partition) clear width

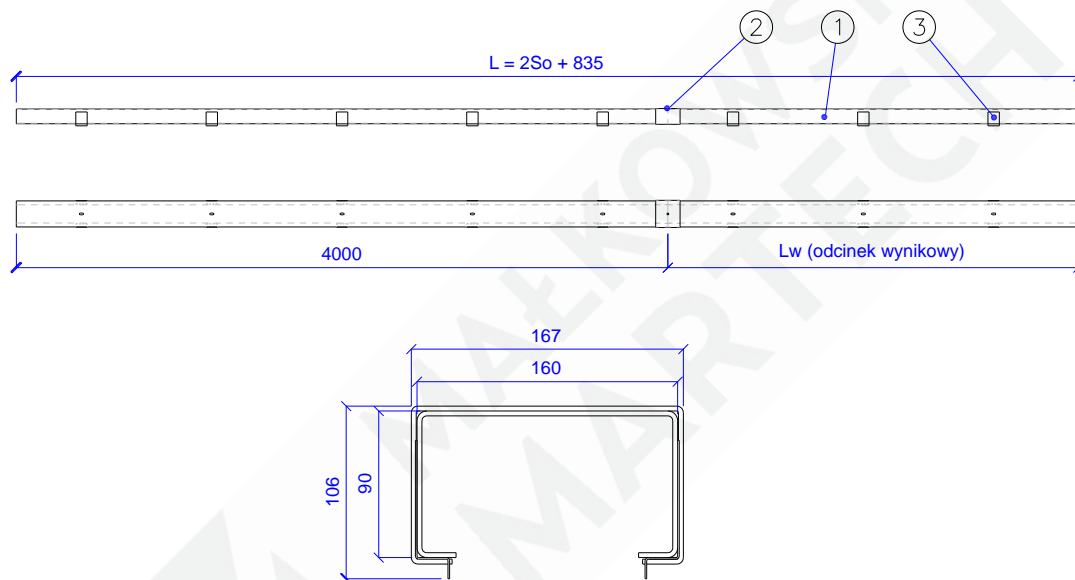
Fig. 4 – MARC-P(1D)120-01.02.00 [Truck rail assembly]

1 – Rail; 2 – Rail union; 3 – Fascia installation profile

Truck rail assembly: list of components

#	Designation	Fig.	Replacement / Repair			Notes
			U ¹⁾	A ²⁾	P ³⁾	
1	Rail profile	1*	-	-	YES	* – In 3 or 4 m sections, plus the end truck rail
2	Rail union	*	-	YES	YES	* – Depends on the door width
3	Guard mounting profile	2*	-	-	YES	* – Every 800 mm

1) – Done by the user, 2) – Done by the authorized service, 3) – Done by the manufacturer

CAUTION! If the parts to be serviced by manufacturer only is replaced by anyone else, it will immediately void the CE marking of the door and the door's performance, including the fire resistance rating.



6.3 TRUCK RAIL BRACKET

The truck rail brackets fasten the truck rail to the construction partition of the building. Each truck rail bracket is made of a 200 × 100 × 10 mm hot-formed angle bar (PN-EN 10056-2). The length of the component is 70 mm and the standard surface finish treatment is galvanizing. The horizontal ledge features tapped holes for M8 × 40 hex head bolts which are intended to facilitate levelling and fastening of the truck rail.

Truck rail bracket specifications

Specification	U.m.	Value	Notes
Width / height / length	mm	200 x 100 x 70	-
Colour	-	galvanized	Any in the RAL palette on request
Quantity	pcs.	*	* – Depending on the door width, every 400–800 mm
Total weight	kg / piece	1.61	-

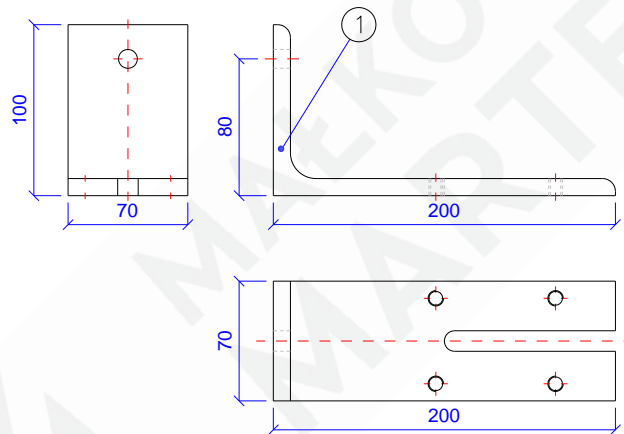

Fig. 5 – MARC–P(1D)120-01.03.00 [Truck rail bracket]

Truck rail bracket: list of components

#	Designation	Fig.	Replacement / Repair			Notes
			U ¹⁾	A ²⁾	P ³⁾	
1	Truck rail bracket	*	-	YES	YES	* – Depends on the door width, every 400–800 mm

1) – Done by the user, 2) – Done by the authorized service, 3) – Done by the manufacturer

CAUTION! If the parts to be serviced by manufacturer only is replaced by anyone else, it will immediately void the CE marking of the door and the door's performance, including the fire resistance rating.



6.4 WALL STOP

The wall stop is a labyrinth meeting edge of the door and made of a Z-profile formed from 2.0 mm thick steel sheet, PN-EN 10346:2015-09 grade DX51D+Z275. An intumescent seal, P/N PRO_{MM}15 is installed along the whole piece.

Wall stop specifications

Specification	U.m.	Value	Notes
Width / height / length	mm	62 / 25 / Ho ¹⁾ + 15	-
Colour	-	galvanized	Any in the RAL palette on request
Quantity	pcs.	1	-
Total weight	kg/m	1.28	-

1) – Door (partition) clear height

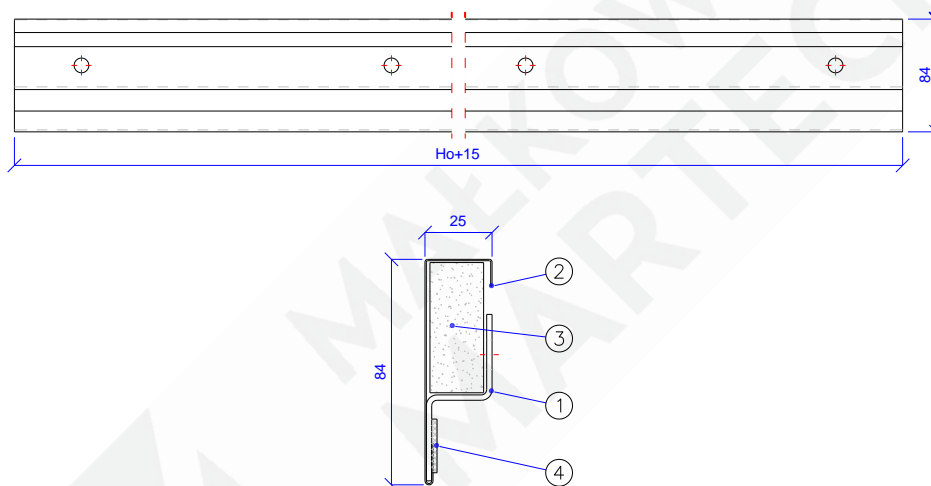

Fig. 6 – MARC-P(1D)120-01.04.00 [Wall stop]

1 – Stop profile; 2 – Intumescent seal

Wall stop: list of components

#	Designation	Fig.	Replacement / Repair			Notes
			U ¹⁾	A ²⁾	P ³⁾	
1	Stop profile	1	-	YES	YES	-
2	Wall stop fascia	1	-	YES	YES	-
3	Fire-proof panel	1	-	YES	YES	-
4	Expanding seal	1	-	YES	YES	PRO _{MM} 15

1) – Done by the user, 2) – Done by the authorized service, 3) – Done by the manufacturer

CAUTION! If the parts to be serviced by manufacturer only is replaced by anyone else, it will immediately void the CE marking of the door and the door's performance, including the fire resistance rating.



6.5 FRONT MODULE

The primary part of the front module is the receiver recess, which is made of 1.0 mm thick steel sheet, PN-EN 10346:2015-09 grade DX51D+Z275. The inside of the receiver recess is lined with 12.5 mm thick fire-proof panels and a fascia flashing of 0.5 mm steel sheet.

In its top part the front module features a union made of 3.0 mm sheet steel, PN-EN 10346:2015-09 grade DX51D+Z275, which is slid into the truck rail. Inside of the union is a bolted cable pulley with a rubber fender. In the back of the front module, the counterweight assembly is suspended on a dia. 3 mm steel cable. The bottom of the receiver recess has a steel run-in ramp bolted to the floor and complete with a rubber fender.

Front module specifications

Specification	U.m.	Value	Notes
Height	mm	$H_o^{1)} + 210$	Depends on the door size
Colour	-	galvanized	Any in the RAL palette on request
Quantity	sets	1	-
Total weight	kg	*	The weight depends on the door size

1) – Door (partition) clear height

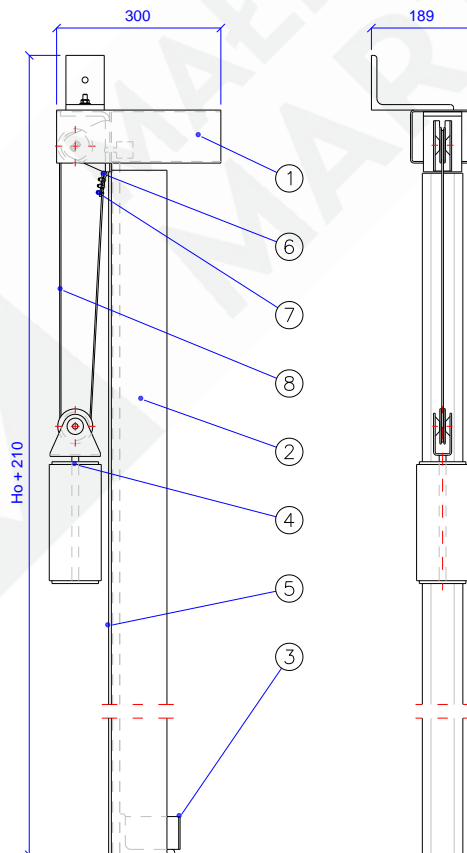

Fig. 7 – MARC-P(1D)120-01.05.00 [Front module]

1 – Truck rail-to-recess union; 2 – Receiver recess; 3 – Run-in ramp; 4 – Counterweight assembly;
 5 – Counterweight guide; 6 – 3 mm thimble; 7 – 3 mm cable bow clamp; 8 – 3 mm steel cable



Front module: list of components

#	Designation	Fig.	Replacement / Repair			Notes
			U ¹⁾	A ²⁾	P ³⁾	
1	Truck rail-to-recess union	1	-	YES	YES	-
2	Receiver recess	1	-	YES	YES	-
3	Run-in ramp	1	-	YES	YES	-
4	Counterweight assembly	1	-	YES	YES	-
5	Counterweight guide	1	-	YES	YES	-
6	3 mm thimble	1	-	YES	YES	DIN 6899 / PN-EN 13411-1+A1
7	3 mm cable bow clamp	3	-	YES	YES	DIN 741
8	3 mm cable, 6 x 7 + FC		-	YES	YES	DIN 3058 / PN-EN 12385-4+A1

1) – Done by the user, 2) – Done by the authorized service, 3) – Done by the manufacturer

CAUTION! If the parts to be serviced by manufacturer only is replaced by anyone else, it will immediately void the CE marking of the door and the door's performance, including the fire resistance rating.

6.6 LOWER RUNNING SHOE

The lower running shoe is intended to keep the door leaf true to the plumb. The lower running shoe comprises a dia. 23 mm steel roller fastened with an M8 bolt to the base which is a 100 × 20 × 10 mm flat bar.

Lower running shoe specifications

Specification	U.m.	Value	Notes
Width / height / length	mm	20 / 40 / 100	-
Colour	-	galvanized	Any in the RAL palette on request
Quantity	pcs.	1	-
Total weight	kg	0.15	-

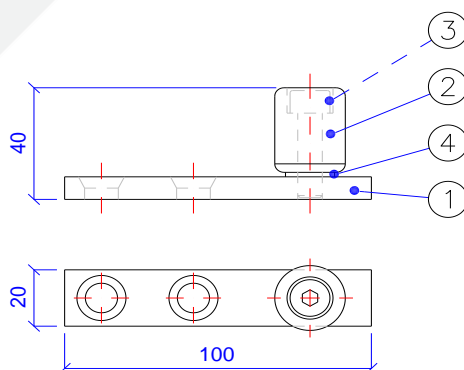

Fig. 8 – MARC-(1D)120-01.06.00 [Lower running shoe]

1 – Base plate; 2 – Guide roller; 3 – M8x25 bolt; 4 – 8.4 mm washer



Lower running shoe: list of components

#	Designation	Fig.	Replacement / Repair			Notes
			U ¹⁾	A ²⁾	P ³⁾	
1	Base plate	1	YES	YES	YES	Replaced as a whole assembly
2	Guide roller	1				
3	M8x25 hex head bolt	1				
4	Washer, 8.4 200 HV	1				

1) – Done by the user, 2) – Done by the authorized service, 3) – Done by the manufacturer

CAUTION! If the parts to be serviced by manufacturer only is replaced by anyone else, it will immediately void the CE marking of the door and the door's performance, including the fire resistance rating.

6.7 E-MAG HOLDER ASSEMBLY

This assembly comprises a bracket made of a 200 × 100 × 10 hot-formed angle bar with the electromagnetic holder bolted to it. The e-mag holder lock is factory-installed on the door leaf.

E-mag holder assembly specifications

Specification	U.m.	Value	Notes
Height / width / length	mm	200 / 70 / 100	-
Colour	-	Galvanized*	* – Applies to the bracket, Any in the RAL palette on request
Quantity	sets	1	-
Total weight	kg	2.5	-

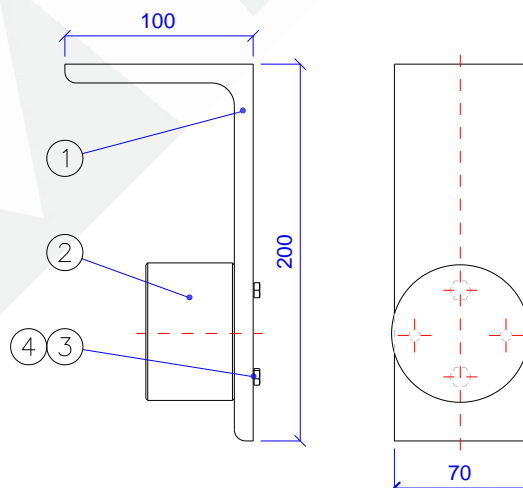
Fig. 9 – MARC-P(1D)120-01.07.00 [E-mag holder assembly]

1 – Holder bracket; 2 – Electromagnetic holder; 3 – M6x16 bolt; 4 – 6.2 mm washer



MAŁKOWSKI MARTECH Czołowo, ul. Leśna 57, 62-035 Kórnik phone: +48 61 222 75 00 fax: +48 61 222 75 01 email: biuro@malkowski.pl, www.malkowski.pl	SLIDING FIRE DOOR type: MARC-P1D EI120	Ref. no.: ISOiK_P-4
	INSTRUCTIONS FOR USE, OPERATION AND MAINTENANCE	Revision: 03/2021

E-mag holder assembly: list of components

#	Designation	Fig.	Replacement / Repair			Notes
			U ¹⁾	A ²⁾	P ³⁾	
1	Holder bracket	1	YES	YES	YES	-
2	Electromagnetic holder	1	YES	YES	YES	The e-mag holder lock is factory installed on the door leaf
3	M6x16 hex head bolt	2	YES	YES	YES	DIN 912 / ISO 4762
-4	6.4 mm plain washer	2	YES	YES	YES	PN-EN ISO 4079

1) – Done by the user, 2) – Done by the authorized service, 3) – Done by the manufacturer

CAUTION! If the parts to be serviced by manufacturer only is replaced by anyone else, it will immediately void the CE marking of the door and the door's performance, including the fire resistance rating.

6.8 HEADER FASCIA

The header fascia conceals the header edge; it is made of 0.7 mm thick steel sheet, PN-EN 10346:2015-09 grade DX51D+Z275, and a fire-proof panel strip.

Header fascia specifications

Specification	U.m.	Value	Notes
Width / height / length	mm	85 / 13 / So ¹⁾ + 100	-
Colour	-	Any in the RAL palette on request	Standard colours: RAL 9002, 9010, 7035
Quantity	sets	1	-
Total weight	kg/m	1.50	-

1) – Door (partition) clear width

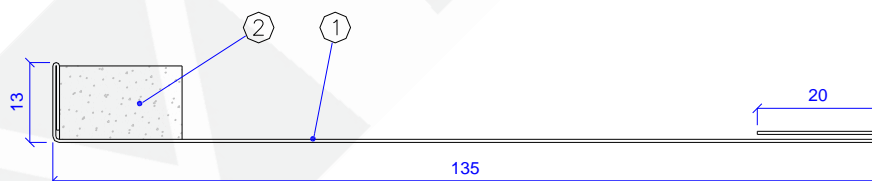

Fig. 10 – MARC-(1D)120-01.08.00 [Header fascia]

1 – Fascia profile; 2 – Fire-proof panel

Header fascia: list of components

#	Designation	Fig.	Replacement / Repair			Notes
			U ¹⁾	A ²⁾	P ³⁾	
1	Fascia profile	1	-	YES	YES	-
2	Fire-proof panel	1	-	YES	YES	-

1) – Done by the user, 2) – Done by the authorized service, 3) – Done by the manufacturer

CAUTION! If the parts to be serviced by manufacturer only is replaced by anyone else, it will immediately void the CE marking of the door and the door's performance, including the fire resistance rating.



6.9 TRUCK RAIL FASCIA

The truck rail fascia conceals the truck rail assembly; it is made of 0.7 to 1.0 mm thick steel sheet, PN-EN 10346:2015-09 grade DX51D+Z275, and a fire-proof panel strip.

Truck rail fascia specifications

Specification	U.m.	Value	Notes
Width / height / length	mm	26 / 195 / 2So ¹⁾ + 660	-
Colour	-	Any in the RAL palette on request	Standard colours: RAL 9002, 9010, 7035
Quantity	sets	1	-
Total weight	kg/m	2.4–2.8*	* – Depending on the thickness of the sheet metal used

1) – Door (partition) clear width

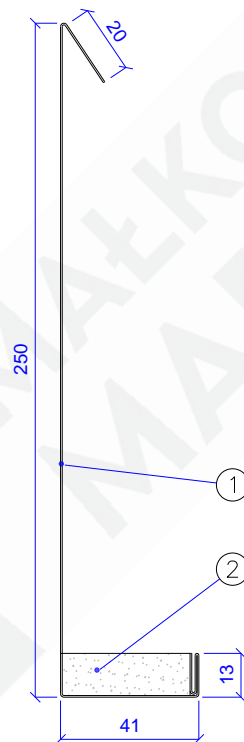

Fig. 11 – MARC-P(1D)120-01.09.00 [Truck rail fascia]

1 – Fascia profile; 2 – Fire-proof panel

Truck rail fascia: list of components

#	Designation	Fig.	Replacement / Repair			Notes
			U ¹⁾	A ²⁾	P ³⁾	
1	Fascia profile	1	YES	YES	YES	-
2	Fire-proof panel	1	YES	YES	YES	-

1) – Done by the user, 2) – Done by the authorized service, 3) – Done by the manufacturer

CAUTION! If the parts to be serviced by manufacturer only is replaced by anyone else, it will immediately void the CE marking of the door and the door's performance, including the fire resistance rating.



MAŁKOWSKI MARTECH Czołowo, ul. Leśna 57, 62-035 Kórnik phone: +48 61 222 75 00 fax: +48 61 222 75 01 email: biuro@malkowski.pl, www.malkowski.pl	SLIDING FIRE DOOR type: MARC-P1D EI120	Ref. no.: ISOiK_P-4
	INSTRUCTIONS FOR USE, OPERATION AND MAINTENANCE	Revision: 03/2021

6.10 FRONT MODULE FASCIA

The front module fascia conceals the front module assembly; it is made of 0.7 to 1.0 mm thick steel sheet, PN-EN 10346:2015-09 grade DX51D+Z275.

Front module fascia specifications

Specification	U.m.	Value	Notes
Width / height / length	mm	235 / 125 / Ho ¹⁾	-
Colour	-	Any in the RAL palette on request	Standard colours: RAL 9002, 9010, 7035
Quantity	sets	1	-
Total weight	kg/m	4.0–5.2*	* – Depending on the thickness of the sheet metal used

1) – Door (partition) clear height

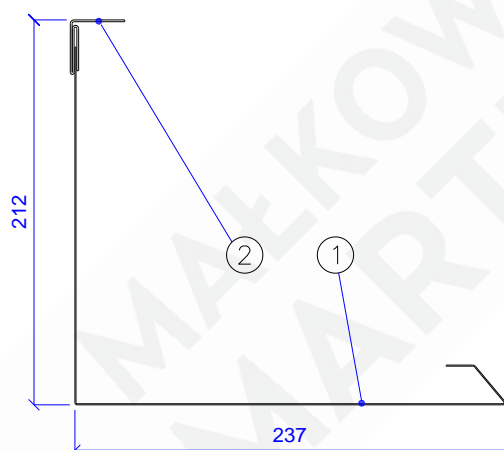

Fig. 12 – MARC-P(1D)120-01.10.00 [Front module fascia]

1 – Fascia profile; 2 – Clip

Front module fascia: list of components

#	Designation	Fig.	Replacement / Repair			Notes
			U ¹⁾	A ²⁾	P ³⁾	
1	Fascia profile	1	YES	YES	YES	-
2	Clip	1	YES	YES	YES	-

1) – Done by the user, 2) – Done by the authorized service, 3) – Done by the manufacturer

CAUTION! If the parts to be serviced by manufacturer only is replaced by anyone else, it will immediately void the CE marking of the door and the door's performance, including the fire resistance rating.

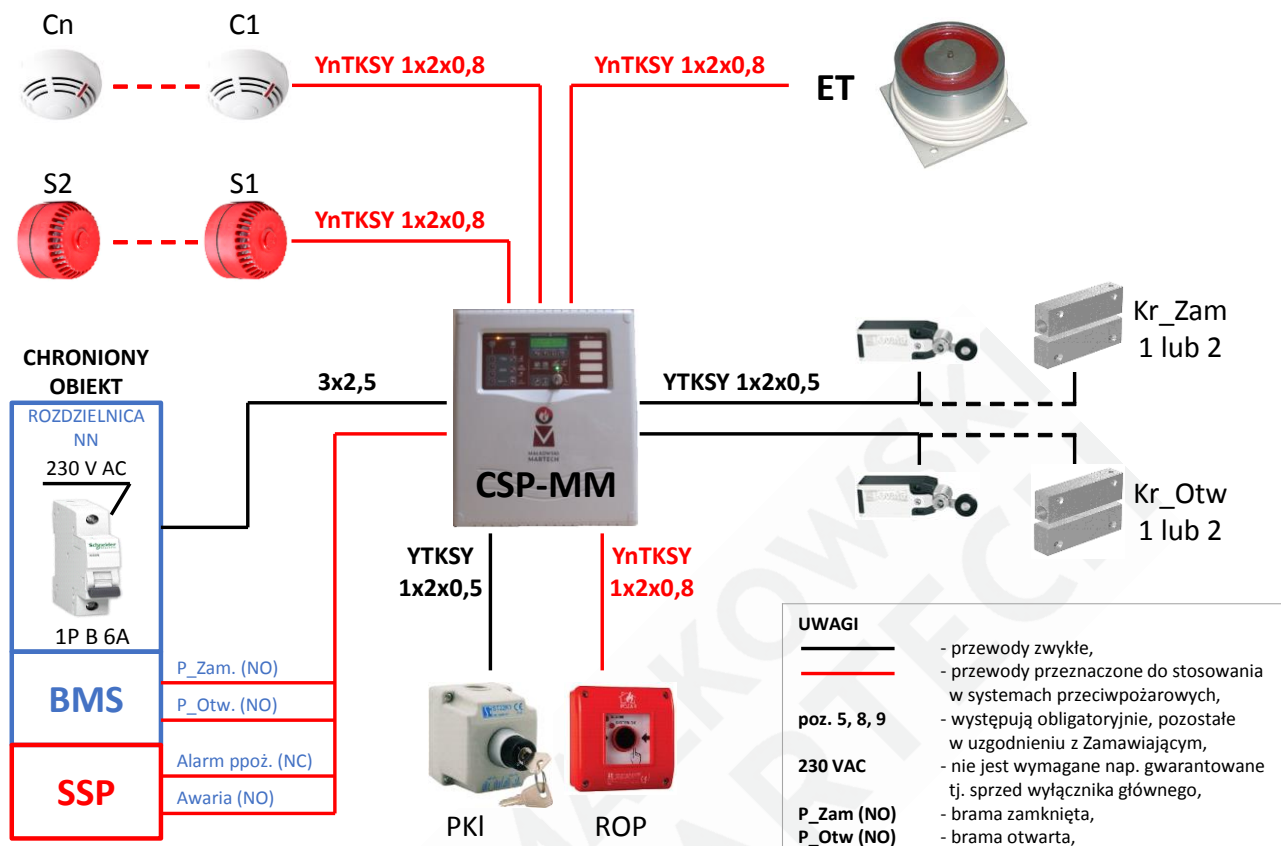

6.11 VIC-EH ELECTRICAL ACCESSORIES KIT

CHRONIONY OBIEKT	MONITORED BLDG
ROZDZIELNICA NN	LV SWITCHGEAR
P_Zam.	G_close
P_Otw.	G_open
Alarm ppoż. (NC)	Fire alarm (NC)
Awaria (NO)	Failure (NO)
UWAGI	NOTES
przewody zwykłe	Regular wires
przewody przeznaczone do stosowania w systemach przeciwpożarowych	Fire alarm system rated wires
występują obligatoryjnie, pozostałe w uzgodnieniu z Zamawiającym	Obligatory, others TBA with the project owner
nie jest wymagane nap. gwarantowane tj. sprzed wyłącznika głównego	Uninterruptible voltage from upstream of the main switch is not required
brama zamknięta	Door / gate closed
brama otwarta	Door / gate open

Fig. 13 – MARC-P1D control system with electromagnetic holder

#	Figure item	Item type	Item designation	Item code	Recommended qty	Notes
1	C1 - Cn	Spot-type fire detector	Optical smoke detector	DRP-100	2	Recommended: DRP-100, max. 32 pcs.
			Class A1R heat detector	DCP-100	2	
			Multi-vector smoke and heat detector	DMP-100	2	
2	C1 - Cn	Detector receptacle	Standard fire detector receptacle	DB100	2	Quantity equal to the number of detectors

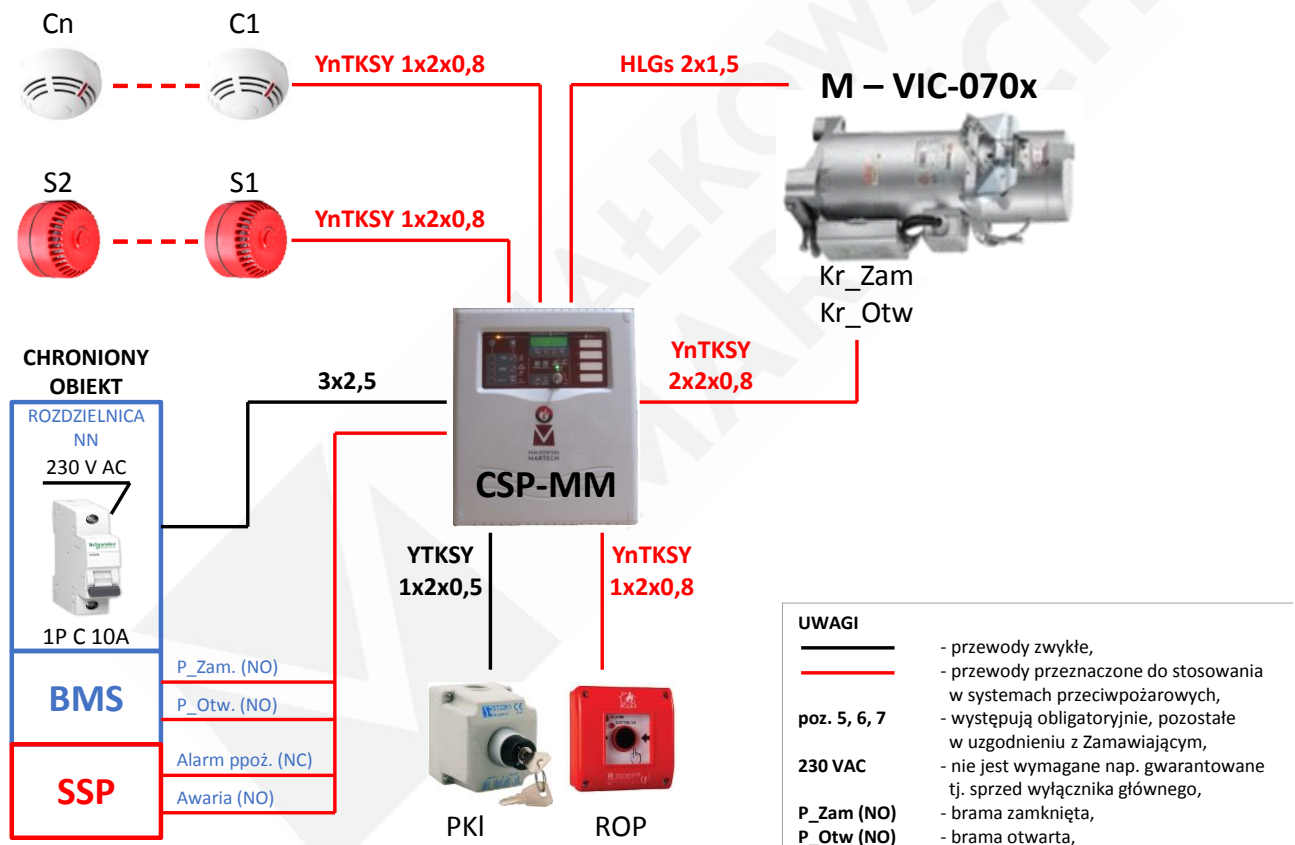

3	ROP	Manual call point	Standard manual call point	ROP-100/PL	1	max. 10 pcs.
4	S1, S2	Fire alarm indicator	Fire alarm sounder, low base	SPP-100	1	max. 2 lines
5	ET	Electromagnetic holder	Land holder	EM-xxxx	1	-
6	LS_close	Limit switch 1 Mag. sensor 2	Mecha. limit switch Magnetic reed relay switch	KB F1 S11 MS-240-S45	1	Application option, selection 1 or 2
7	LS_open	Limit switch 1 Mag. sensor 2	Mecha. limit switch Magnetic reed relay switch	KB F1 S11 MS-240-S46	1	Application option, selection 1 or 2
8	PKI	Key switch	Key operated switch K1, hand operation	SP22K1/07-1	1	-
9	CSP-MM	Control unit	Universal drive controller	CSP-MM 1(2)	1	-

6.12 VIC-0701 ELECTRICAL ACCESSORIES KIT

CHRONIONY OBIEKT	MONITORED BLDG
ROZDZIELNICA NN	LV SWITCHGEAR
P_Zam.	G_close
P_Otw.	G_open
Alarm ppoż. (NC)	Fire alarm (NC)
Awaria (NO)	Failure (NO)
UWAGI	NOTES
przewody zwykłe	Regular wires
przewody przeznaczone do stosowania w systemach przeciwpożarowych	Fire alarm system rated wires
występują obligatoryjnie, pozostałe w uzgodnieniu z Zamawiającym	Obligatory, others TBA with the project owner
nie jest wymagane nap. gwarantowane tj. sprzed wyłącznika głównego	Uninterruptible voltage from upstream of the main switch is not required



MAŁKOWSKI MARTECH Czołowo, ul. Leśna 57, 62-035 Kórnik phone: +48 61 222 75 00 fax: +48 61 222 75 01 email: biuro@malkowski.pl, www.malkowski.pl	SLIDING FIRE DOOR type: MARC-P1D EI120	Ref. no.: ISOIK_P-4
	INSTRUCTIONS FOR USE, OPERATION AND MAINTENANCE	Revision: 03/2021

brama zamknięta	Door / gate closed
brama otwarta	Door / gate open

Fig. 14 – MARC-P1D control system with externally-mounted 24 V DC drive unit

Version I – power-assisted closing and opening motion; **Version II** – Counterweight-assisted closing motion; power-assisted opening motion

#	Figure item	Item type	Item designation	Item code	Recommended qty	Notes
1	C1 - Cn	Spot-type fire detector	Optical smoke detector	ID100	2	Recommended: ID100 max. 6 pcs.
			Class A1R heat detector	ID200	2	
			Smoke and heat detector	ID300	2	
2	C1 - Cn	Detector receptacle	Standard fire detector receptacle	EB0010	2	Quantity equal to the number of detectors
3	ROP	Manual call point	Standard manual call point	ROP OP1	1	max. 10 pcs.
4	S1, S2	Fire alarm indicator	Fire alarm sounder, low base	SPP-100	1	max. current 200 mA
5	M	Electric drive	internal (tubular)	VIC-070x	1	-
6	PKzM	Console	Remote console	PKzM	1	-
7	CSP-MM	Control unit	Universal drive controller	CSP-MM 1(2)	1	-

7. TROUBLESHOOTING

Every failure of the fire door shall be reported to the manufacturer and removed by authorized personnel strictly as instructed by the manufacturer (ref. Section 8 INSPECTION, MAINTENANCE, AND REPAIRS).

Fault type	Fault cause(s) / operating error	Remedy by operators
Door leaf fails to close	The truck rail assembly is obstructed or damaged	Call the Technical Service to clear or replace the running rail
	Structural component damage	Call the Technical Service to repair or replace the failed part(s)
	Counterweight stuck or its cable is broken	
The man door fails to close	Spring-action hinge failure	Call the Technical Service to repair or replace the failed part(s)
	Door closer damaged / poorly adjusted	
Fire detector inoperative / fails to trigger the control system	Dirty or damaged	Call the Technical Service to clean, readjust, or replace the part(s)



MAŁKOWSKI MARTECH Czołowo, ul. Leśna 57, 62-035 Kórnik phone: +48 61 222 75 00 fax: +48 61 222 75 01 email: biuro@malkowski.pl, www.malkowski.pl	SLIDING FIRE DOOR type: MARC-P1D EI120	Ref. no.: ISOiK_P-4
	INSTRUCTIONS FOR USE, OPERATION AND MAINTENANCE	Revision: 03/2021

Fault type	Fault cause(s) / operating error	Remedy by operators
Fire alarm sounder/beacon fails to come on	System component failure	
Local control system (control panel) indicates an error		Call the Technical Service to troubleshoot
Manual call point does not work / has failed	MCP glass broken	Call the Technical Service to replace the part(s)

8. INSPECTION, MAINTENANCE, AND REPAIRS

8.1 INSPECTION & MAINTENANCE SCHEDULE

The fire door shall be inspected, maintained and repaired by personnel with sufficient qualifications and professional experience for these tasks.

The fire door manufacturer or its authorized installation contractors (ref. the guidelines in Section 1 INTRODUCTION and Section 2.4 SERVICE PERSONNEL REQUIREMENTS in this Manual) provide paid service inspections, maintenance, repairs, and troubleshooting according to the specific sales contract. This personnel have the required technical resources, spare parts, and qualifications.

Send your service requests for these tasks to the MAŁKOWSKI-MARTECH S.A. Technical Service, (serwis@malkowski.pl or fax: + 48 61 22 27 501). The Technical Service contact details are also on the manufacturer's official website and in the Warranty Certificate.

The inspections and maintenance must be done in compliance with this Manual (ref. the guidelines in the schedule tables below) to ensure correct and safe operation; they are prerequisite to maintain the declared performance of the sliding fire door and during the warranty period, otherwise the warranty rights and liability will be made void.

Inspection type	Frequency	Ownership
Pre-operation inspection	Before each use (does not apply to a fire emergency)	Operator
Monthly inspection	Every 1 month	
Service inspection and maintenance	Every 6 months	Authorized technical service

S – Check, inspect, clean; **X** – Adjust and lubricate

Inspection & maintenance schedule

Assembly / component	Tasks required	Before each use	Every 1 month	Every 6 months
Whole product				
Product structure	Check the painted surfaces (for dirt, etc.) and clean as required.		S	S
	Check that no part is missing and there is no evidence of damage of failure from operation.	S	S	S
	Check the door's identification markings (the nameplate must be present and legible).		S	S
Door leaf.	Check for dirt, damage, etc.; clean as required.	S	S	S



MAŁKOWSKI MARTECH Czołowo, ul. Leśna 57, 62-035 Kórnik phone: +48 61 222 75 00 fax: +48 61 222 75 01 email: biuro@malkowski.pl, www.malkowski.pl	SLIDING FIRE DOOR type: MARC-P1D EI120	Ref. no.: ISOIK_P-4
	INSTRUCTIONS FOR USE, OPERATION AND MAINTENANCE	Revision: 03/2021

Brackets, guards, fascias	Check the fasteners and their condition			S
Door leaf closing/opening drive				
Truck rail assembly	Check the fasteners and the component's condition; look for obstructions.			S
Counterweight system	Check the cable fastening and condition.			S
	Check that the movement is unobstructed; lubricate as required ¹⁾ .		S	S
Electrical / control system				
All electrical accessories	Trigger the sensors/detectors to test for proper operation of the accessories kit; readjust as required.			SX
Fire detector	Check the condition and clean the component; readjust as required.			SX
Manual call point	Check the condition and test the operation.			S
Control unit (panel)	Test the operation of all control panel components.			S
	Check for error displays.	S	S	S
Key switch	Check the condition and test the operation.		S	S
Electric drive motor	Check the condition and test the operation (the component must run smoothly and without stuttering, audible noise, and evident vibration).		S	S
Battery pack	Inspect the terminals and wiring; clean and lubricate as required ¹⁾ .		S	SX
	Check the battery acid level and state of charge; refill with battery acid and recharge as required.		S	S
Electrical wiring system ²⁾	Inspect the fastening and condition of fittings and cable trays.		S	S

1) – Petroleum jelly is recommended.

2) – Power wiring insulation resistance tests and wiring continuity tests are to be done at least every 5 years.

All worn or damaged parts shall be replaced with new counterparts only. Maintain and repair with genuine components and parts which are approved by the fire door manufacturer. Each inspection, maintenance, and repair shall be completed and certified by the authorized personnel according to the scheduled scope in the Periodic Inspection and Maintenance Log (appended to this Manual in the chapter 11 – APPENDICES) or in a separate certificate.

The fire door user shall retain all records of inspections, maintenance, repairs, and overhauls.

8.2 OPERATOR'S INSPECTIONS

The operator's inspections shall be done by the operator assigned by the product's user and trained by the fire door manufacturer or its authorized installation contractor (ref. also the guidelines in Section 2.4 SERVICE PERSONNEL REQUIREMENTS and Section 8.1 INSPECTION & MAINTENANCE SCHEDULE).

Wear basic PPE (personal protection equipment) e.g. rubber gloves etc. during each inspection service.

If the fire door fails, is damaged, or found to operate incorrectly, notify the site supervisors and the manufacturer or its authorized installation contractor.

8.3 SERVICE INSPECTIONS & MAINTENANCE

The technical services of the manufacturer are provided by qualified and professionally experienced service technicians of MAŁKOWSKI-MARTECH S.A. or its contractors who are authorized for servicing the fire door.

To verify for the buyer that the service is provided by a fully professional/authorized contractor or technician, the latter should hold and present their Installation Authorization Certificate, while the service technicians



MAŁKOWSKI MARTECH Czołowo, ul. Leśna 57, 62-035 Kórnik phone: +48 61 222 75 00 fax: +48 61 222 75 01 email: biuro@malkowski.pl, www.malkowski.pl	SLIDING FIRE DOOR type: MARC-P1D EI120	Ref. no.: ISOiK_P-4
	INSTRUCTIONS FOR USE, OPERATION AND MAINTENANCE	Revision: 03/2021

should hold and present their Site Authorized Service Certificate issued by the fire door manufacturer, MAŁKOWSKI-MARTECH S.A.

In the Lists of Components and Parts, ref. Section 6 TECHNICAL SPECIFICATIONS of this Manual, the fire door manufacturer specifies the ownership and right of repair/replacement of components, assemblies, and parts; failure in compliance to these specifications will void the product warranty and declaration of performance.

CAUTION!

Pursuant to the Polish Regulation ref. Dz.U.2010.109.719, as amended: §3.2 “Fire protection equipment (...) shall be technically inspected and maintained in compliance with the procedures and methods established in the Polish Standards [PN] concerning fire protection equipment and fire extinguishers, the equipment’s operating and maintenance manuals, and the user manuals issued by the respective equipment manufacturers.” §3.3 “Technical inspections and maintenance shall be carried out with the frequency established by the respective manufacturer and at least once a year.”

The service inspections, maintenance, repairs, and overhaul of the fire door shall only be done by trained personnel of the manufacturer or its authorized service contractor.

The fire door user or the personnel or contractor it has authorized is liable for collection and retention of documented proof that the service inspections and maintenance are carried out at least every six months, unless specified otherwise in the sale contract (or special requirements/site conditions of the user require other frequency of the service inspections and maintenance).

8.4 CLEANING

The operating personnel is required to keep the work place and the fire door clean. Clean with commercially available household cleaning products, e.g. dishwashing liquids.

Do not use aggressive cleaners or organic solvents, or pressure washing (with water or other liquids). If the fire door is contaminated with insoluble substances, remove them mechanically without damage to the paint coat or scratching the product’s surfaces.

8.5 REPLACEMENT PARTS

Order the replacement parts by specifying the production year of the fire door and the part numbers, designations, and quantity.

ALL REPLACEMENT PARTS USED FOR INSPECTION, MAINTENANCE, REPAIRS, AND OVERHAULS SHALL BE GENUINE SPARE PARTS SPECIFIED BY THE MANUFACTURER IN THE LISTS OF “COMPONENTS AND PARTS” IN SECTION 6 TECHNICAL SPECIFICATIONS OF THIS MANUAL.

9. DISPOSAL

Dispose of the fire door and all its worn out parts in compliance with applicable regulations of law.

When the fire door or any of its parts reaches its end of life and requires dismantling and disposal:

- Remove the door components and electrical system by performing the assembly and installation in the reverse order, and follow by handing over the parts (like the electric motor) for waste recovery.
- Hand over all plastic, rubber, and mineral wool parts for disposal.
- Cut and scrap the steel structure, metal sheets, profiles, bars and other hardware with all other steel parts (including anchors, plugs, and bolts).

9.1 CHEMICAL NOTICE

None of the sliding fire door components contains asbestos or coatings or elements which release any gases harmful to the ozone layer. The pigments and anti-corrosive treatment of the structure and components are free of cadmium, chromium and other air and soil aquifer layer pollutants.



MAŁKOWSKI MARTECH Czołowo, ul. Leśna 57, 62-035 Kórnik phone: +48 61 222 75 00 fax: +48 61 222 75 01 email: biuro@malkowski.pl, www.malkowski.pl	SLIDING FIRE DOOR type: MARC-P1D EI120	Ref. no.: ISOiK_P-4
	INSTRUCTIONS FOR USE, OPERATION AND MAINTENANCE	Revision: 03/2021

10. IDENTIFICATION

Type MARC-P1D single-leaf sliding fire door is identified with the nameplate the specimen of which is shown below. The parameters of the delivered fire door are featured on the nameplate.



 2434
 MAŁKOWSKI MARTECH MAŁKOWSKI-MARTECH S.A. Czołowo ul. Leśna 57 62-035 Kórnik 20 Declaration of Performance No./CPR/MARC-P/2020 - PL
EN 16034:2014 Fire door, single-leaf, sliding MARC®-P1D EI120 Intended use: Installation in fire partitions Fire resistance: EI ₂ 120 Ability to release: Released Self-closing rating: C Ability to release durability: Sustained release Self-closing durability related to degradation: Use category: Self-closing durability related to weathering (corrosion) Achieved EN 13241:2003+A2:2016 Resistance to wind load: Class
Serial number: / 202...

Fig. 15 – Specimen of the nameplate of the sliding fire door (ref. EN 16034:2014-11)

The nameplate is factory applied on the door leaf, near the flush pull.



11. APPENDICES

- Periodic Inspection and Maintenance Log
- Warranty Certificate (SPECIMEN)
- Copy of the Declaration of Performance
- Available to the manufacturer-issued Installation Authorization Certificate holders:
 - VIC electrical accessories kit installation manual
 - Type MARC-P1D EI120 sliding fire door installation manual



PERIODIC INSPECTION AND MAINTENANCE LOG

Equipment type:	Serial number:	Year of production:
-----------------	----------------	---------------------

#	Completed service(s)	Date & authorized stamp and signature	Notes
1			
2			
3			
4			
6			
7			
8			
9			
10			
11			
12			
13			
14			
15			
16			
17			
18			
19			
20			



MAŁKOWSKI MARTECH Czołowo, ul. Leśna 57, 62-035 Kórnik phone: +48 61 222 75 00 fax: +48 61 222 75 01 email: biuro@malkowski.pl, www.malkowski.pl	SLIDING FIRE DOOR type: MARC-P1D E1120	Ref. no.: ISOiK_P-4
	INSTRUCTIONS FOR USE, OPERATION AND MAINTENANCE	Revision: 03/2021

WARRANTY CERTIFICATE

Warranty issued to the Buyer / Warranty Rights Owner*:		Installation location*:		
Warranty period*:		Ref. Contract/P.O. No.*:		
#	Sold product	Additional description*:	Identification no.*:	Quantity (pcs)*:
1	Single-leaf sliding fire door, MARC-P1D E1120	E1260		1
2	Local control system (control panel)	CSP M-M		1
3	Fire detector, thermal	DRP-100		2
4	Manual call point	ROP-100/PL		1
5	Alarm sounder & beacon	SPP-100		1

§ 1

Shipping; acceptance; pre-installation work

1. The quantity acceptance of the product is done prior to outbound shipping and at the site of MAŁKOWSKI-MARTECH S.A. (hereinafter, the GUARANTOR). The signature of the Installer/Buyer on the Goods Issue Note provided with the sold product certifies that the product is complete and conforms with the specifications in the Goods Issue Note.
2. Before the product is assembled/installed, the Installer shall carefully verify that the product has not been damaged in transport, remains of full value, and conforms to the purchase order submitted by the Buyer. If the product is found not to be conformity with the purchase order and/or any defect is found in the product, do not proceed with the assembly and installation process; immediately notify the Guarantor.
3. If the product's defect(s) could have been reasonably found with due diligence prior to the assembly and installation process, all WARRANTY CLAIMS for the defect(s) submitted once the product is assembled and installed will be rejected without examination.

§ 2

General warranty terms and conditions

1. The Warranty Rights Owner will retain its warranty rights provided that:
 - a) The sold product is assembled and installed by the Guarantor or a contractor who holds the Installation Authorization Certificate (issued by the Guarantor), and the assembly and installation process is certified with the relevant entry on the last page of this Warranty Certificate;
 - b) Periodic service inspections are ordered (pursuant to a separate service contract) for the product under this Warranty and to be performed by the Guarantor or the (manufacturer's) Service Authorization Certificate holder according to this schedule:
 - Every 6 months – when the product remains in its fully closed or open position without cyclic operation;
 - Every 3 months – when the product is operated in any way different than above and in compliance with the criteria established by the Guarantor in the service contract;
2. These warranty terms and conditions apply to the product sold by the Guarantor and purchased, assembled, and installed in the Republic of Poland.
3. The service inspections specified in § 2.1 above are payable.
4. Within 14 days after each service inspection completed by the Service Authorization Certificate holder, the Warranty Rights Owner shall provide the copies of the service inspection certificates to the Guarantor:
 - a) by e-mail at serwis@malkowski.pl, and
 - b) to the Guarantor's registered office address, or the warranty rights will be made void.
5. The warranty period begins on the date of certified post-assembly and installation acceptance of the product.
6. The rights granted under this Warranty do not include the right to claim damages for lost profits or compensation



for any damage related to the failure of the product, except for the rights granted under this Warranty.

§ 3

Procedure of warranty claims and exercise of warranty rights

1. The Warranty Rights Owner is required to report each defect discovered in the product, which shall be done in writing and in 14 days after the discovery.
2. Each warranty claim shall be submitted to the Guarantor in writing or be null and void.
3. Each warranty claim submission shall include:
 - a) a copy of the Warranty Certificate;
 - b) A detailed account of the discovered defects, its causes, and conditions in which they have emerged;
 - c) The product serial number;
 - d) Proof of completion of the periodic service inspections of the product as specified in § 2.4.
4. To ensure smooth warranty claim processing, it is recommended to attach photographic evidence of the defective product to facilitate examination.
5. The Warranty Rights Owner shall provide all conditions required for and facilitating repair of the claimed product (especially by permitting access to the product and removal from service of all equipment which can be hazardous to the personnel removing the claimed defects).
6. Failure to submit a warranty claim by the time specified in § 3.1 will release the Guarantor from the obligation of processing the warranty claim.

§ 4

Warranty rights

1. If the warranty claim made under the Warranty is reasonable, the Guarantor shall, at its own discretion, remove the defects of the product (by repairing it) or replace the product (or its affected part) with a new counterpart.
2. The title of the replaced defective products will become property of the Guarantor.
3. If defects or failures are discovered during the warranty period and prevent use of the product, the Guarantor shall act as reasonably required to remove the defects or failures in 10 business days from the date of claim.
4. If defects or failures are discovered during the warranty period and DO NOT prevent use of the product, the Guarantor shall act as reasonably required to remove the defects or failures in 20 business days from the date of claim.
5. The time limits specified in § 4.3 and § 4.4 can be extended due to reasonably important causes, especially whenever:
 - a) the parts necessary for the execution of the warranty rights are not available on the market;
 - b) it is necessary to import some or all parts from abroad to process the warranty claim;
 - c) reasons beyond any control of the Guarantor arise, of which the Warranty Rights Holder will be advised.
6. Business days shall be understood as days from Monday to Friday, excluding holidays and other statutory work-free days.
7. If, in the performance of its obligations, the Guarantor supplies the Warranty Rights Holder with an item free of defects instead of a defective item, or has made significant repairs of an item on warranty, the warranty period for the item shall run again from the date of delivery of the item free of defects or the return of the repaired item to the Warranty Rights Holder.
8. The warranty for the replaced items shall start again from the date of delivery of the item free of defects or repaired, with respect to the replaced item.
9. The replacement of parts/items shall not result in extension of the warranty period for the whole product sold.
10. The Guarantor is entitled to charge the Warranty Rights Holder with the costs of an unreasonable warranty claim (which is unreasonable if the claimed defect does not exist or the claim features a request for remedying a defect not covered by this Warranty).
11. The costs referred to in § 4.10 specifically include the costs of service travel to the product's site and the costs of removal of the defects, if any.
12. The costs of defect removal not covered by this Warranty will be evaluated according to the price list of the Guarantor.

§ 5

Exclusion of warranty rights

This Warranty does not cover:

1. any defects caused by anything not in the sold product;



2. defects caused by any tampering with the sold product by the Warranty Rights Owner or a third party, especially alterations and modifications without prior written authorisation of the Guarantor; if the sold product is tampered with, the WARRANTY AND THE DECLARATION OF PERFORMANCE are void;
3. defects caused by misuse / non-intended use of the product or failure in routine maintenance of the product, especially any use or maintenance in deviation from the manuals of the product to which this Warranty Certificate is attached;
4. defects resulting from assembly or repairs performed by personnel not authorized by the Guarantor;
5. the product installed on a site under this Warranty with failure to provide service inspections by the Guarantor or the Service Authorisation Certificate;
6. parts of the product which are naturally worn, partially or completely, according to the properties or the intended use (these include running assembly parts, electrical batteries, etc.);
7. mechanical damage of the product and the defects resulting from it;
8. defects caused by defects of the structure in which the product has been installed;
9. incorrect selection of the product to the conditions at the installation site;
10. defective operation of the installed equipment which has not been provided by the Guarantor, and resulting in negative impact on the product. Should any of the foregoing occurs, THE DECLARATION OF PERFORMANCE ISSUED FOR THE PRODUCT AND ITS WARRANTY CERTIFICATE are automatically void and null;
11. defects resulting from the external factors, especially fire, extreme weather, and fortuitous event;
12. damage caused by misuse of the product or its operation in deviation from the operating manuals, which also includes operation beyond the maximum performance limits;
13. use of non-genuine spare parts, which are parts not original to the Guarantor;
14. the product sold if this Warranty Certificate is redacted or defaced in any way;
15. the product sold if its nameplate is removed, damaged, or modified;
16. the product with its warranty seal is damaged or removed.

.....
Date and signature of the Guarantor's Installation Authorisation Certificate Holder

.....
Authorization no. and date of issue

